

INDEX

SHEET NO.	SUBJECT
1	Signs Drawing Index and General Notes
2	Route Marker Details, Shields and Auxiliary Signs
3	Route Marker Details, Arrow and Cardinal Direction Signs
4	Sign Reflectorization Schedule
5	Sign Reflectorization Schedule
6	Miscellaneous Sign Details
7	Steel Sign Posts, Selection Table
8	Steel Sign Posts, Bracing for Signs Greater Than 90"
9	Steel Sign Posts, Anchor Base Details
10	Sign Identification Marking

GENERAL NOTES:

1. Characters sometimes cannot be accommodated within the space available on guide signs. For this situation, the standard series D characters may be reduced to series C. As a second choice, use the next smaller height commonly available.
2. For independent use of sheet signs, a nylon and metal washer shall be placed between each bolt head and the face of the metal sign. See Sign Bolt Detail on Standard Drawing E 802-SNGS-06.
3. Fabrication details for the signs shown shall be found in the Standard Highway Signs and Markings Book. Shop drawings will be supplied on all other signs not found in the publication.
4. See Standard Drawing E 802-SNPL-02 for mounting height and lateral locations of signs.
5. Splicing of flanged channel post will not be permitted.
6. Wherever white is specified as a color, it is understood to include silver-colored reflecting coatings or elements that reflect white light.

INDIANA DEPARTMENT OF TRANSPORTATION

SIGNS
DRAWING INDEX AND GENERAL NOTES

SEPTEMBER 2026

STANDARD DRAWING NO. E 802-SNGS-01

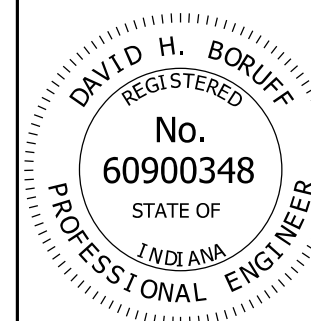

 4/28/2026
 DESIGN STANDARDS ENGINEER DATE

 04/29/2026
 CHIEF ENGINEER DATE



WHITE BACKGROUND WITH BLACK BORDER AND NUMERALS

M1-4(I)



WHITE BACKGROUND WITH BLACK NUMERALS

M1-4(G)

(G) INDICATES SHIELD TO BE USED ON ALL GUIDE SIGNS AND DOES NOT REQUIRE BLACK BORDER



WHITE BACKGROUND WITH BLACK LETTERS, NUMERALS AND BORDER

M1-5



WHITE LETTERS, NUMERALS, AND BORDER

M1-1

FOR INDEPENDENT USE ONLY

FOR GUIDE SIGN USE

STATE ROUTE MARKER

INTERSTATE SHIELD

M1-4(I), M1-4(G), M1-5, M1-1					
12" NUMERALS		18" NUMERALS		24" NUMERALS	
2 DIGITS	3 DIGITS	2 DIGITS	3 DIGITS	2 DIGITS	3 DIGITS
24" x 24"	30" x 24"	36" x 36"	45" x 36"	48" x 48"	60" x 48"

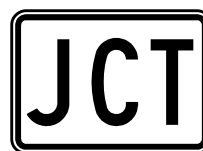

M2-1P(S)
M2-1P(I)



M4-5P(I)
M4-5P(S)



M4-6P(S)
M4-6P(I)



M4-4P(S)

(I) INDICATES WHITE LEGEND ON BLUE BACKGROUND (INTERSTATE)
(S) INDICATES BLACK LEGEND ON WHITE BACKGROUND (STATE)

STATE	M2-1P(S)		M4-4P(S)		M4-5P(S)		M4-6P(S)	
INTERSTATE	M2-1P(I)				M4-5P(I)		M4-6P(I)	
SHIELD SIZES	24" x 24"	36" x 36"	24" x 24"	36" x 36"	24" x 24"	36" x 36"	24" x 24"	36" x 36"
	30" x 24"	45" x 36"	30" x 24"	45" x 36"	30" x 24"	45" x 36"	30" x 24"	45" x 36"
CORRESPONDING SIGN SIZE	21" x 15"		24" x 12"	36" x 18"	24" x 12"	36" x 18"	24" x 12"	36" x 18"

NOTES:

1. All series M(S) "JCT", "TO", "TRUCK", and "END" shall be white background with black legend and border.
2. All series M(I) "JCT", "TO", "TRUCK", and "END" shall be blue background with white legend and border.
3. Center align numbers about vertical centerline of shield.

INDIANA DEPARTMENT OF TRANSPORTATION	
ROUTE MARKER DETAILS SHIELDS AND AUXILLARY SIGNS	
SEPTEMBER 2026	
STANDARD DRAWING NO.	E 802-SNGS-02
	 DESIGN STANDARDS ENGINEER 4/28/2026 DATE
	 CHIEF ENGINEER 04/29/2026 DATE

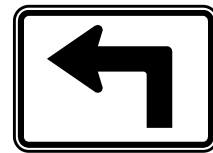

M5-1P (R or L) (I or S)

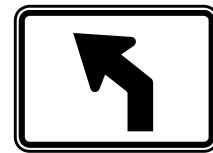

M5-2P (R or L) (I or S)

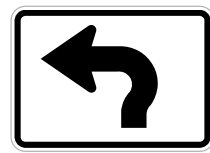

M5-3P (R or L) (I or S)

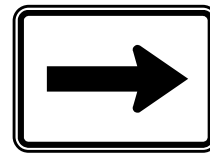

M6-1P (R or L) (I or S)



M6-5P (R or L) (I or S)



M6-2P (R or L) (I or S)

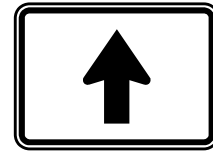

M6-3P (I or S)

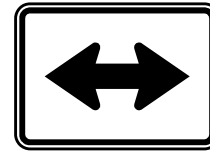

M6-4P (I or S)

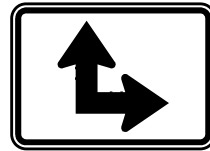

M6-6P (R or L) (I or S)

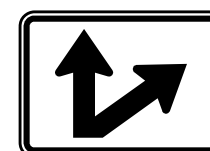

M6-7P (R or L) (I or S)

NOTES:

1. All series M(S) cardinal directions and arrows shall be white background with black legend and border.
2. All series M(I) cardinal directions and arrows shall be blue background with white legend and border.
3. Make 1st letter 10% taller.

STATE	M5-1P(S) M6-1P(S) M6-3P(S) M6-5P(S) M6-7P(S) M5-2P(S) M5-3P(S) M6-2P(S) M6-4P(S) M6-6P(S)			
INTERSTATE	M5-1P(I) M6-1P(I) M6-3P(I) M6-5P(I) M6-7P(I) M5-2P(I) M5-3P(I) M6-2P(I) M6-4P(I) M6-6P(I)			
SHIELD SIZES	24" x 24" 30" x 24"		36" x 36" 45" x 36"	
CORRESPONDING SIGN SIZE	21" x 15"		30" x 21"	



M3-1P (S or I) ③



M3-2P (S or I) ③



M3-3P (S or I) ③



M3-4P (S or I) ③

STATE	M3-1P(S) M3-2P(S) M3-3P(S) M3-4P(S)			
INTERSTATE	M3-1P(I) M3-2P(I) M3-3P(I) M3-4P(I)			
SHIELD SIZES	24" x 24"	30" x 24"	36" x 36"	45" x 36"
CORRESPONDING SIGN SIZE	24" x 12"	24" x 12"	36" x 18"	36" x 18"

INDIANA DEPARTMENT OF TRANSPORTATION

ROUTE MARKER DETAILS
ARROW AND CARDINAL DIRECTION SIGNS

SEPTEMBER 2026

STANDARD DRAWING NO. E 802-SNGS-03

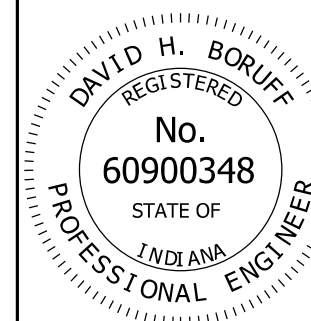

David H. Boruff 4/28/2026
 DESIGN STANDARDS ENGINEER DATE

[Signature] 04/29/2026
 CHIEF ENGINEER DATE



SIGN	REMARKS	BACKGROUND	COPY & BORDER
IGD, IGDO, GD	Directional	S-3-H	B
IGI	Information	S-4-H	B
IGS	Services	S-4-H	B
IGDO, GDO Special Panel	Warning Panel	S-10-H	A
R1-1, R1-3P	Stop Sign and All Way Plaque	S-5-H	S-2-H
R1-2	Yield Sign	S-2-H	S-5-H
R1-5	Yield Here to Pedestrians	S-2-H	S-5-H, O-1-H
R1-6	In-Street Yield Here to Pedestrians	S-10-H	S-2-H, S-5-H, O-1-H
R1-9	Overhead Yield to Pedestrians	S-2-H	S-10-H, O-1-H
R2-3P	Night Speed Limit Plaque	O-1-H	S-2-H
R3-1, R3-2, R3-4, R3-18, R3-27	Movement Prohibition Signs	S-2-H	S-5-H, O-1-H
R5-1	Do Not Enter	S-5-H	S-2-H
R5-1a	Wrong Way	S-5-H	S-2-H
R5-2, R5-6, R9-13 thru R9-16	Selective Exclusion Signs	S-2-H	S-5-H, O-1-H
R7-1, R7-4, R7-107, R7-201P	No Parking (Urban)	S-2-H	S-5-H
R7-2a, R7-107a	No Parking (Urban)	S-2-H	S-5-H, O-1-H
R7-5, R7-5a, R7-108	Restricted Parking	S-2-H	S-7-H
R7-8	Reserved Parking	S-2-H	S-7-H, S-6-H
R8-1, R8-1a, R8-2, R8-3, R8-3b, R8-3c, R8-8	No Parking (Rural)	S-2-H	S-5-H
R8-3a	No Parking (Rural)	S-2-H	S-5-H, O-1-H
R9-3, R9-4	Pedestrian Signs	S-2-H	S-5-H, O-1-H
R10-3b thru R10-3i	Pedestrian Pushbutton Signs	S-2-H	S-9-H, O-1-H
All other regulatory signs		S-2-H	O-1-H
W3-1a, W3-2a	Stop & Yield Ahead	S-10-H	S-2-H, S-5-H, O-1-H
W3-3	Signal Ahead	S-10-H	S-5-H S-7-H, O-1-H
All School Warning Signs		S-11-H	O-1-H
All other warning signs	Except Construction Signs, School Warning Signs	S-10-H	O-1-H
M1-1	Interstate Shields	S-8-H	S-2-H
M1-2, M1-3	Business Shields	S-7-H	S-2-H
M1-4	U.S. Shields	S-2-H	O-1-H
M1-5	State Shields	S-2-H	O-1-H
M1-6	County Shields	S-4-H	S-1-H
M1-7	National Forest	△	S-2-H

BACKGROUND, COPY & BORDER KEY

CODE	DESCRIPTION
0-1-H	Paint (Black) For Use With Prismatic Reflective Sheeting
S-1-H	Prismatic Reflective Sheeting (Yellow)
S-2-H	Prismatic Reflective Sheeting (Silver)
S-3-H	Prismatic Reflective Sheeting (Green)
S-4-H	Prismatic Reflective Sheeting (Blue)
S-5-H	Prismatic Reflective Sheeting (Silver with reverse screen transparent Red)
S-6-H	Prismatic Reflective Sheeting (Silver with reverse screen transparent Blue)
S-7-H	Prismatic Reflective Sheeting (Silver with reverse screen transparent Green)
S-8-H	Prismatic Reflective Sheeting (Silver with reverse screen transparent Red and Blue)
S-9-H	Prismatic Reflective Sheeting (Fluorescent Orange)
S-10-H	Prismatic Reflective Sheeting (Fluorescent Yellow)
S-11-H	Prismatic Reflective Sheeting (Fluorescent Yellow-Green)
A	Cut - Out Letters Which Are Painted Black
B	Cut - Out Letters and Border - White Prismatic Reflective Sheeting
△	Brown Background with Prismatic Reflective Sheeting

SIGN IDENTIFICATION CODES

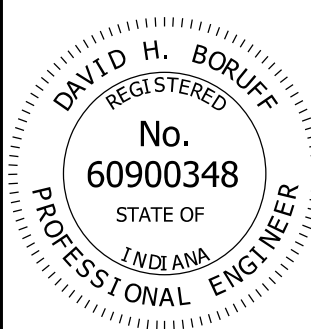
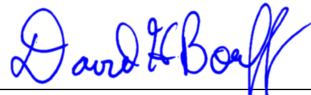
- IGDO Interstate Guide Directional Overhead
- IGD Interstate Guide Directional
- IGS Interstate Guide Service and Rest Area
- IGI Interstate Guide Information
- GDO Guide Directional Overhead
- GD Guide Directional
- R Regulatory Sign
- W Warning, Construction and Maint. Signs
- M Route Markers and Aux. Markers for Assemblies
- D Destination Sign
- I Information

INDIANA DEPARTMENT OF TRANSPORTATION	
SIGN REFLECTORIZATION SCHEDULE	
SEPTEMBER 2026	
STANDARD DRAWING NO.	E 802-SNGS-04
	 4/28/2026 DESIGN STANDARDS ENGINEER DATE
	 04/29/2026 CHIEF ENGINEER DATE



BACKGROUND, COPY AND BORDER KEY

SIGN	REMARKS	BACKGROUND	COPY & BORDER
M2-1P (I), M3-1P (I), M3-2P (I), M3-3P (I), M3-4P (I)	Auxiliary Markers	S-6-H	S-2-H
M4-5P (I), M4-7P (I), M5-1P (I), M5-2P (I)	Auxiliary Markers	S-6-H	S-2-H
M6-1P thru M6-7P	Auxiliary Markers	S-6-H	S-2-H
M4-5P, M4-6P	Auxiliary Markers	S-7-H	S-2-H
M4-8, M4-9	Detour Marker	S-9-H	O-1-H
All Other Marker Auxiliaries		S-2-H	O-1-H
D4-1	Parking	S-2-H	S-7-H
D5 Series, D9 Series, D12 Series	Rest Area, Service, Info	S-6-H	S-2-H
D7-2	Recreation Area	△	S-2-H
All Other Destination Signs		S-3-H	S-2-H
I-17, I-18, I-19		S-6-H	S-2-H
I-20, I-21		S-2-H	O-1-H
All Other I-Signs		S-7-H	S-2-H
All Construction Signs		S-9-H	O-1-H
All Maintenance Signs		S-9-H	O-1-H

CODE	DESCRIPTION
O-1-H	Paint (Black) For Use With Prismatic Reflective Sheeting
S-1-H	Prismatic Reflective Sheeting (Yellow)
S-2-H	Prismatic Reflective Sheeting (Silver)
S-3-H	Prismatic Reflective Sheeting (Green)
S-4-H	Prismatic Reflective Sheeting (Blue)
S-5-H	Prismatic Reflective Sheeting (Silver with reverse screen transparent Red)
S-6-H	Prismatic Reflective Sheeting (Silver with reverse screen transparent Blue)
S-7-H	Prismatic Reflective Sheeting (Silver with reverse screen transparent Green)
S-8-H	Prismatic Reflective Sheeting (Silver with reverse screen transparent Red and Blue)
S-9-H	Prismatic Reflective Sheeting (Fluorescent Orange)
A	Cut - Out Letters Which Are Painted Black
B	Cut - Out Letters And Border - White Prismatic Reflective Sheeting
△	Brown Background With Prismatic Reflective Sheeting

SIGN IDENTIFICATION CODES

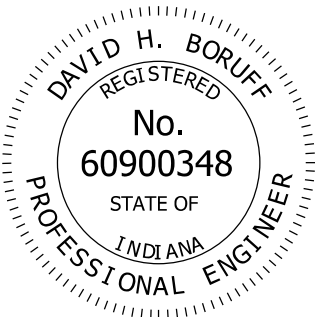
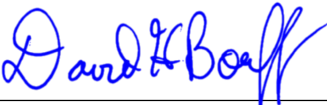
- IGDO Interstate Guide Directional Overhead
- IGD Interstate Guide Directional
- IGS Interstate Guide Service and Rest Area
- IGI Interstate Guide Information
- GDO Guide Directional Overhead
- GD Guide Directional
- R Regulatory Sign
- W Warning, Construction and Maint. Signs
- M Route Markers and Aux. Markers for Assemblies
- D Destination Sign
- I Information

INDIANA DEPARTMENT OF TRANSPORTATION	
SIGN REFLECTORIZATION SCHEDULE	
SEPTEMBER 2026	
STANDARD DRAWING NO. E 802-SNGS-05	
	<div style="text-align: right;">  DESIGN STANDARDS ENGINEER 4/28/2026 DATE </div> <div style="text-align: right; margin-top: 20px;">  CHIEF ENGINEER 04/29/2026 DATE </div>

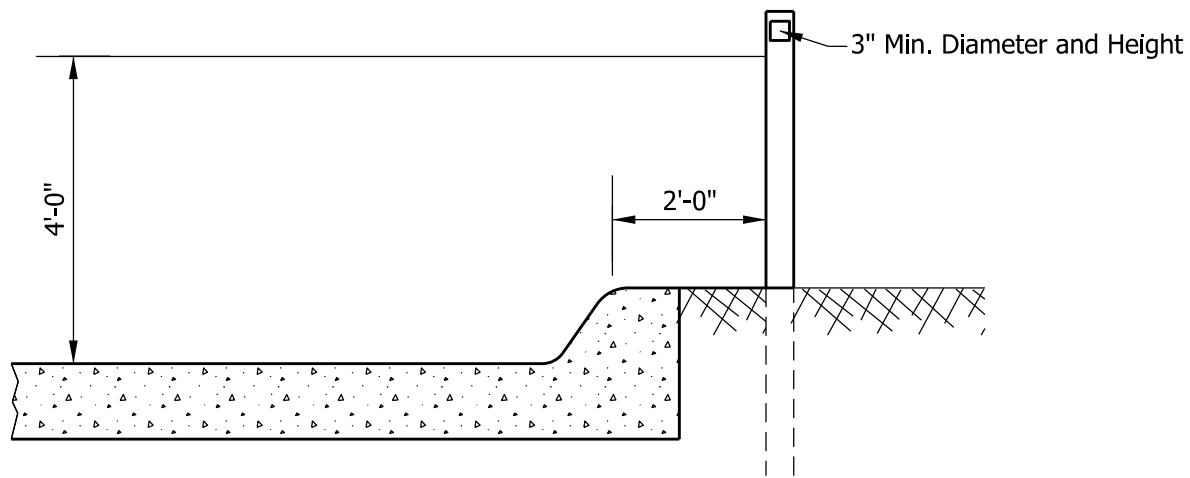

CURB SECTION

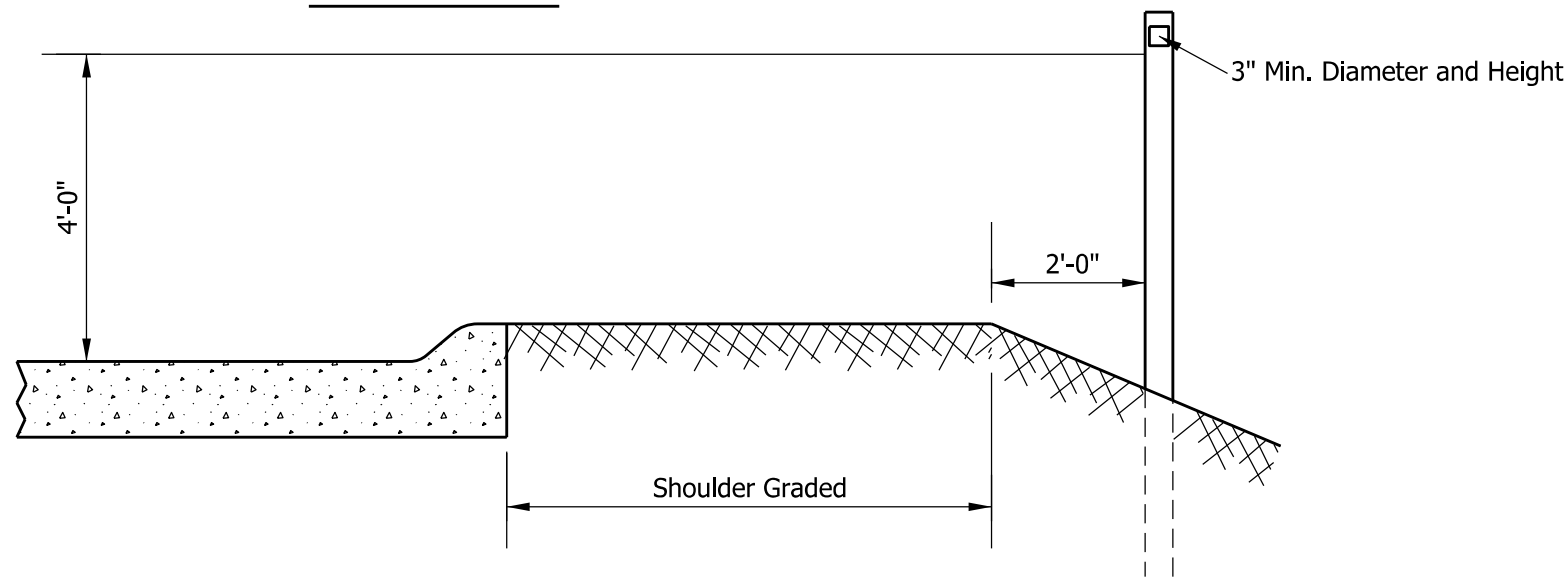

SLOPING CURB SECTION

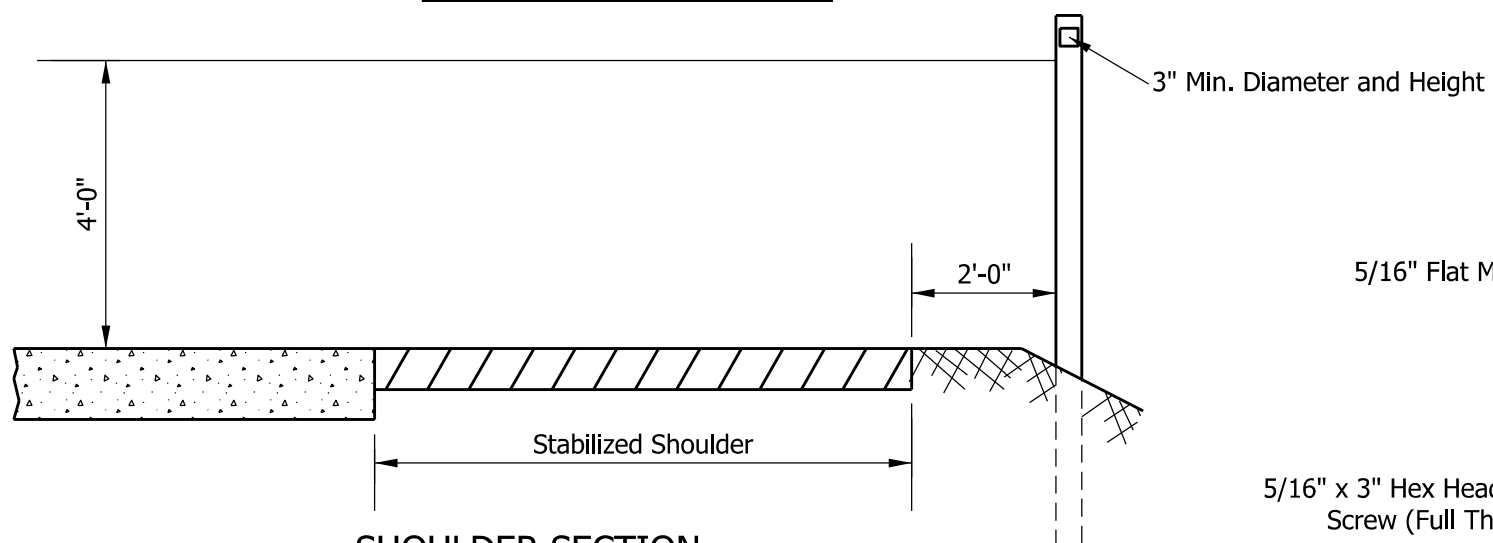

SHOULDER SECTION

DELINEATOR DETAILS ②

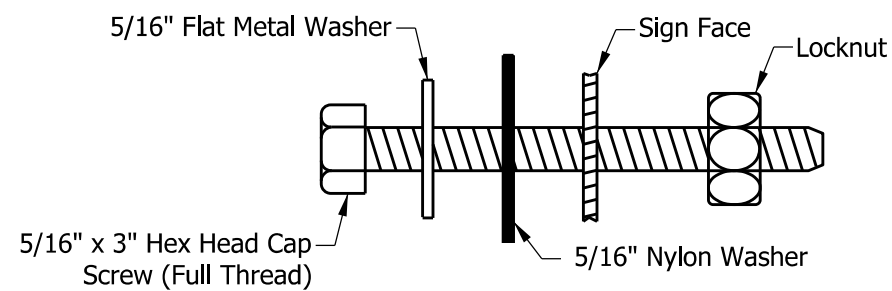

SIGN BOLT DETAIL

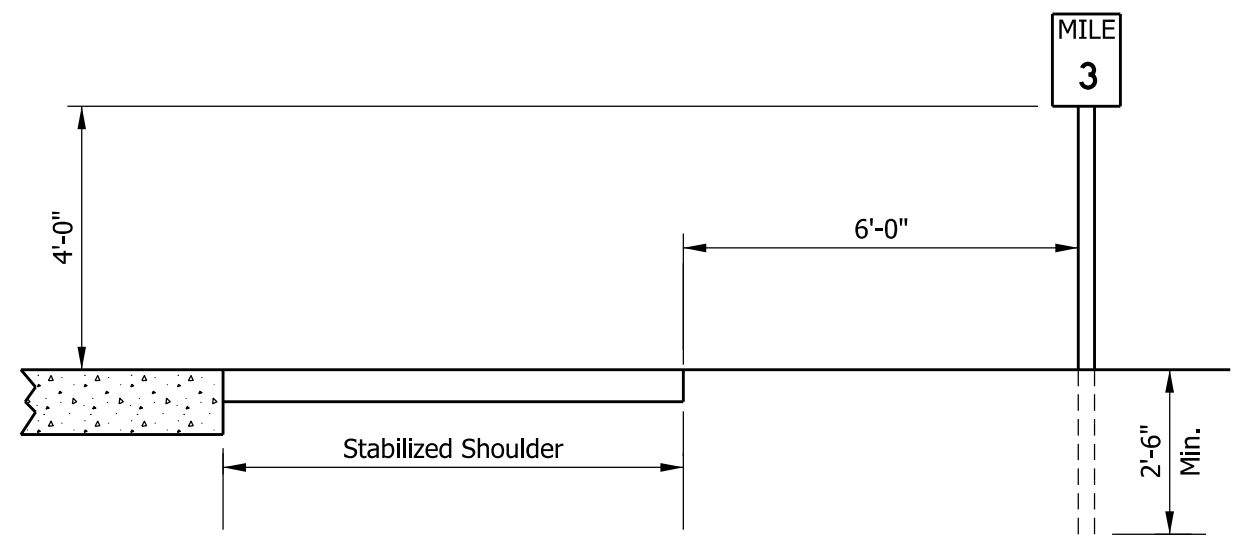

TYPICAL MILE OR REFERENCE POST ①

NOTES:

- ① Reference markers shall be installed in accordance with MUTCD.
- ② Delineators shall be selected from the INDOT Qualified Products List.
3. Signs shall be fastened to the posts with bolts, metal and nylon washers and locknut. The nylon washer and the metal washer shall be placed between each bolt head and the face of the sign.
4. Nut shall be tightened sufficiently so that the sign is firmly against the post. However, there shall be no deformation of aluminum sheeting or twisting or damage to the reflective sheeting.
5. Bolt can either be stainless steel or galvanized steel bolt.

INDIANA DEPARTMENT OF TRANSPORTATION

MISCELLANEOUS SIGN DETAILS

SEPTEMBER 2026

STANDARD DRAWING NO. E 802-SNGS-06

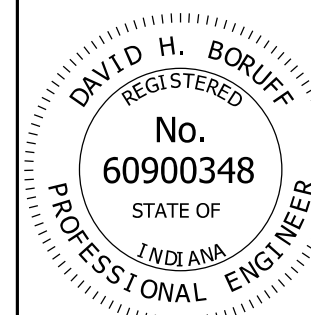

David H. Boruff
DESIGN STANDARDS ENGINEER DATE 4/28/2026

[Signature]
CHIEF ENGINEER DATE 04/29/2026

MOUNTING HEIGHT								
WIDTH X HEIGHT ("W X H")	5 FT		6 FT		7 FT		8 FT	
	U CHANNEL	SQUARE POST	U CHANNEL	SQUARE POST	U CHANNEL	SQUARE POST	U CHANNEL	SQUARE POST
12 x 12, 12 x 6, 12 x 9 12 x 12, 12 x 18, 12 x 30	1-A	1-Type 1	1-A	1-Type 1	1-A	1-Type 1	1-A	1-Type 1
12 x 36	1-A		1-A		1-A		1-A	
18 x 6, 18 x 12, 18 x 18	1-A		1-A		1-A		1-A	
18 x 24	1-A		1-A		1-A		1-A	
18 x 30	1-A		1-A		1-A		1-A	
18 x 48	1-A		1-A		1-A		1-A	
24 x 12, 24 x 18, 24 x 24	1-A		1-A		1-A		1-A	
24 x 30	1-A		1-A		1-A		1-A	
24 x 36	1-A		1-A		1-A		1-A	
30 x 18	1-A		1-A		1-A		1-A	
30 x 24	1-A		1-A		1-A		1-A	
30 x 30	1-A		1-A		1-A		1-A	
30 x 36	1-A		1-A		1-A		1-A	
30 x 42	1-B		1-B		1-B		1-B	
30 x 48	1-B		1-B		1-B		1-B	
36 x 12	2-A		2-A		2-A		2-A	
36 x 18	2-A		2-A		2-A		2-A	
36 x 24	2-A		2-A		2-A		2-A	
36 x 36	2-A		2-A		2-A		2-A	
36 x 48	2-A		2-A		2-A		2-A	
42 x 18	2-A		2-A		2-A		2-B	
42 x 24	2-A		2-A		2-A		2-A	
42 x 30	2-A		2-A		2-A		2-A	
42 x 36	2-A		2-A		2-A		2-A	
48 x 16	2-A		2-A		2-A		2-A	
48 x 18	2-A		2-A		2-A		2-A	
48 x 24	2-A		2-A		2-A		2-A	
48 x 30	2-A		2-A		2-A		2-A	
48 x 36	2-A	2-Type 2	2-A	2-Type 2	2-A	2-Type 2	2-A	2-Type 2
48 x 48	2-A		2-B		2-B		2-B	
48 x 60	2-B		2-B		2-B		2-B	
60 x 24	2-A		2-A		2-A		2-A	
60 x 30	2-A		2-A		2-A		2-A	
60 x 36	2-A		2-A		2-B		2-B	
60 x 48	2-B	2-B	2-B	2-B				
72 x 24	2-A	2-A	2-A	2-A				
72 x 36	2-B	2-B	2-B	2-B				
90 x 36 120 x 36	2-B	2-Type 3	2-B	2-Type 3	2-B	2-Type 3	2-B	2-Type 3

NOTES:

1. See Standard Drawing E 802-SNGS-08 and -09 for square steel sign post installation details.
2. The Type 1 post shall be 2 1/4 in. x 2 1/4 in. x 12 ga. wall thickness.
3. The Type 2 post shall be 2 in. x 2 in. x 12 ga. wall thickness.
4. The Type 3 post shall be 2 1/2 in. x 2 1/2 in. x 12 ga. wall thickness.
5. Flanged channel posts are as specified and as shown on the plans.

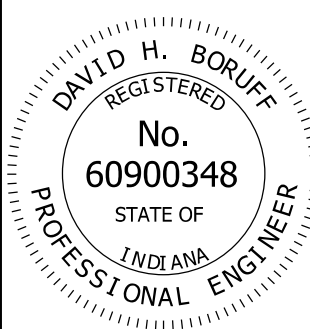
INDIANA DEPARTMENT OF TRANSPORTATION	
STEEL SIGN POST SELECTION TABLE	
SEPTEMBER 2017	
STANDARD DRAWING NO.	E 802-SNGS-07
	<i>/s/ David H. Boruff</i> 03/16/17 DESIGN STANDARDS ENGINEER DATE
	<i>/s/ John Leckie</i> 04/10/17 CHIEF ENGINEER DATE

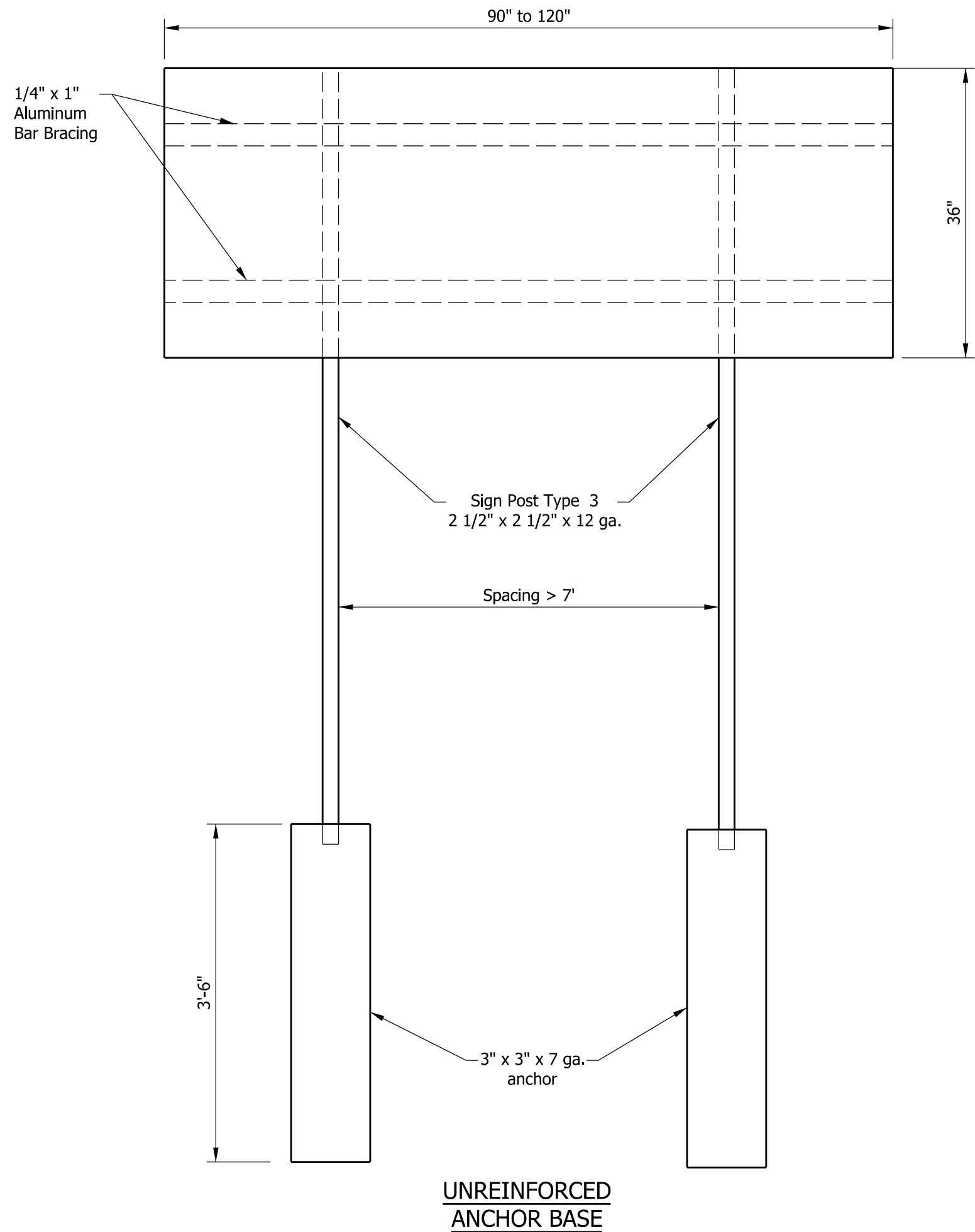

NOTES:

1. Maximum sign width 120", maximum sign area 30 sq. ft.

INDIANA DEPARTMENT OF TRANSPORTATION

STEEL SIGN POSTS
BRACING FOR SIGNS GREATER THAN 90"

SEPTEMBER 2017

STANDARD DRAWING NO. E 802-SNGS-08

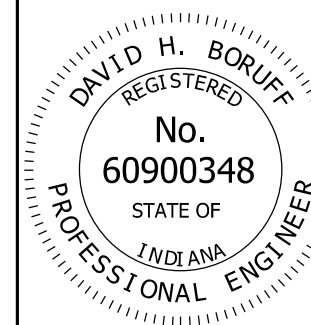

/s/ David H. Boruff 03/16/17
DESIGN STANDARDS ENGINEER DATE

/s/ John Leckje 04/10/17
CHIEF ENGINEER DATE

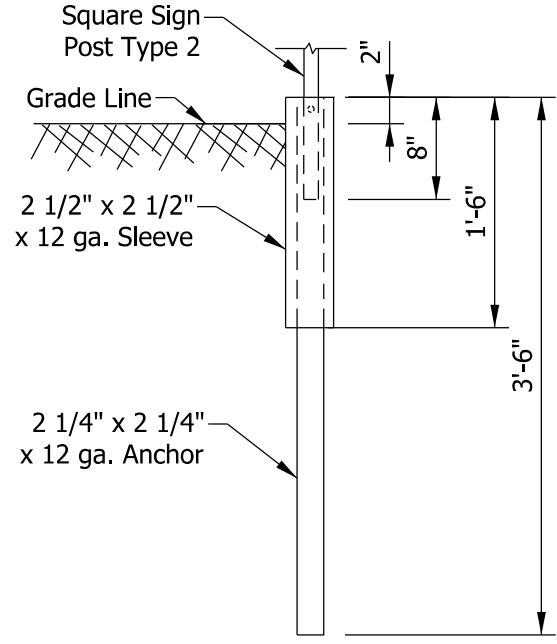

REINFORCED ANCHOR BASE

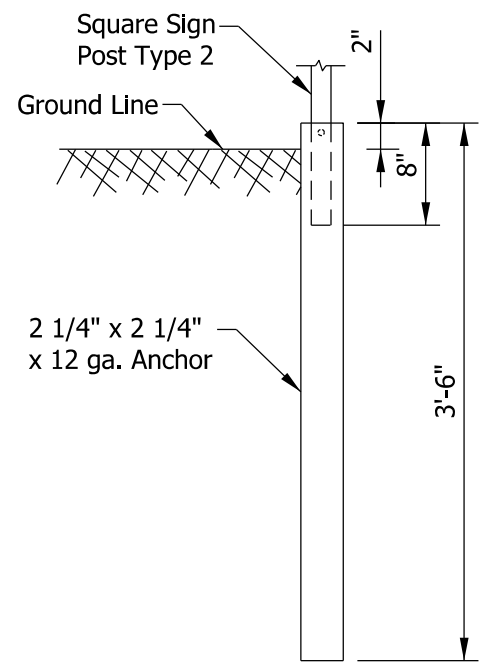

UNREINFORCED ANCHOR BASE

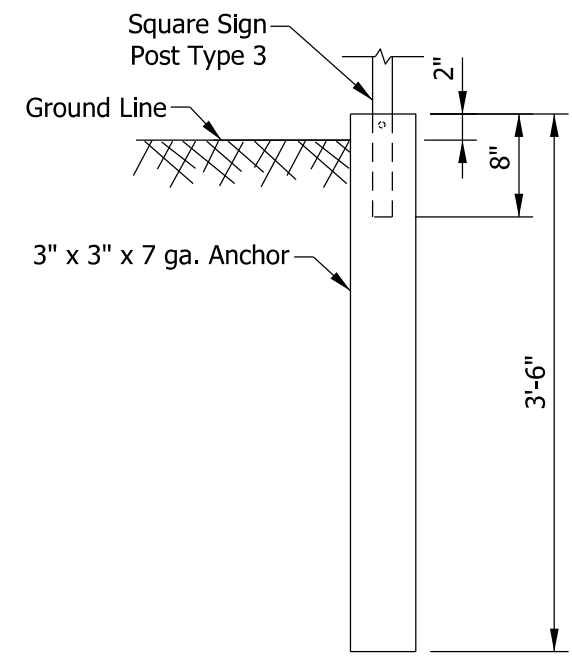

UNREINFORCED ANCHOR BASE

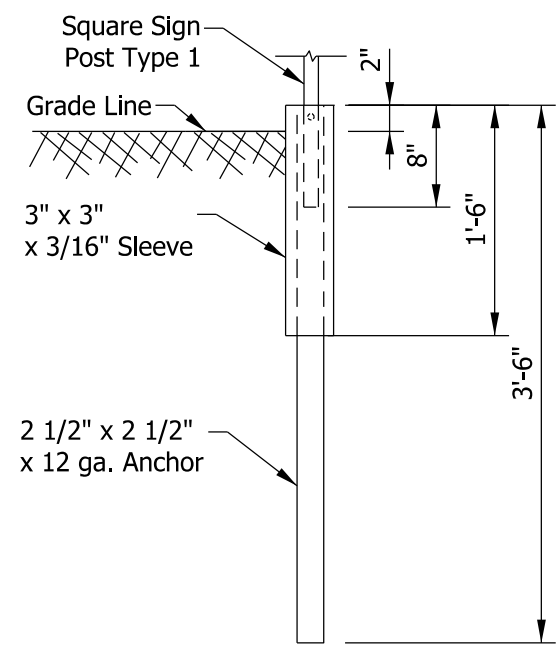

REINFORCED ANCHOR BASE

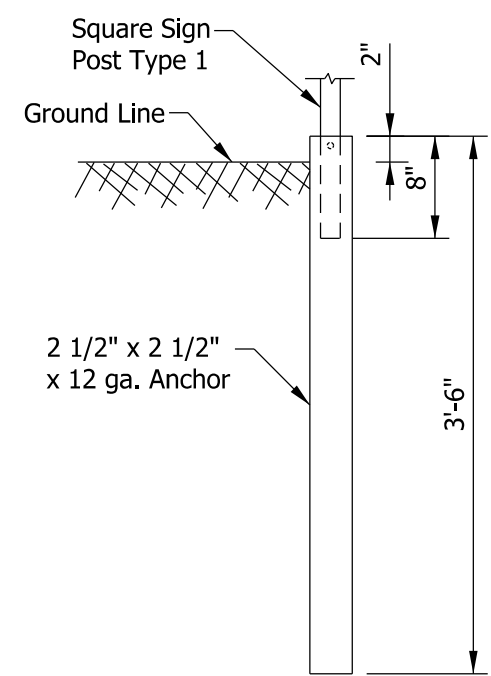

UNREINFORCED ANCHOR BASE

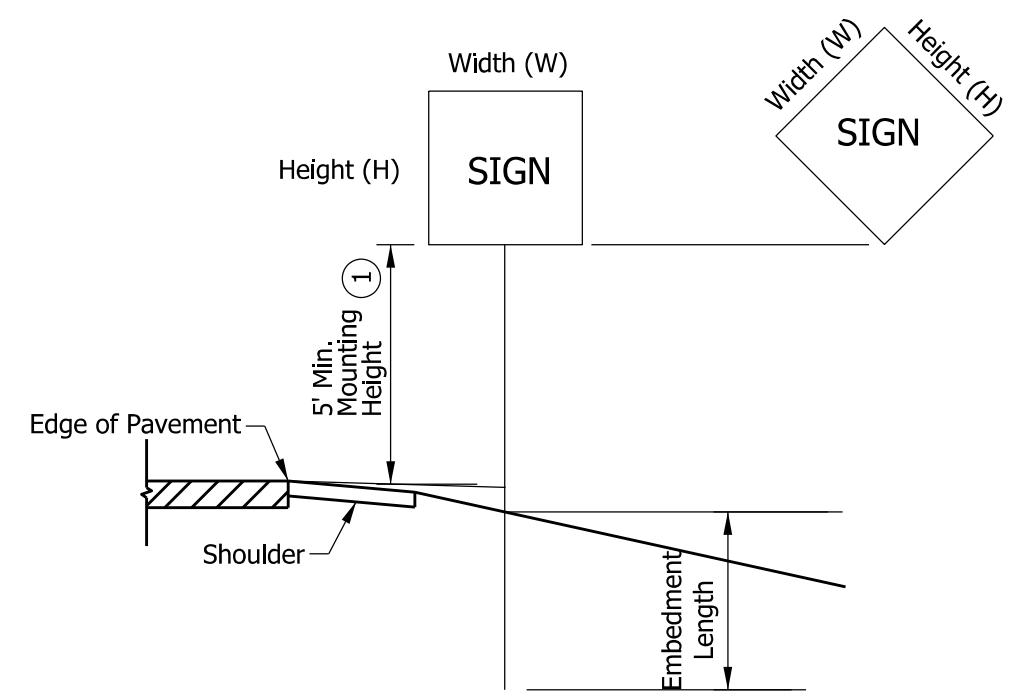

NOTES:

- ① See Standard Drawing E 802-SNGS-07 for sign size and E 802-SNPL-02 for horizontal and vertical sheet sign clearance.

POST	TYPE	WALL THICKNESS	NO. OF POSTS PERMITTED IN 7 ft PATH	EMBEDMENT LENGTH
U-CHANNEL	A, B	X	1 OR 2	3'-6"
SQUARE	1	12 ga.	1	Anchor Base
	2	12 ga.	1 OR 2	
	3	12 ga.	1	

INDIANA DEPARTMENT OF TRANSPORTATION									
STEEL SIGN POSTS ANCHOR BASE DETAILS									
SEPTEMBER 2017									
STANDARD DRAWING NO.	E 802-SNGS-09								
	<table style="width: 100%; border: none;"> <tr> <td style="width: 80%; border: none;">/s/ David H. Boruff</td> <td style="width: 20%; border: none;">03/16/17</td> </tr> <tr> <td style="border: none;">DESIGN STANDARDS ENGINEER</td> <td style="border: none;">DATE</td> </tr> <tr> <td style="border: none;">/s/ John Leckje</td> <td style="border: none;">04/10/17</td> </tr> <tr> <td style="border: none;">CHIEF ENGINEER</td> <td style="border: none;">DATE</td> </tr> </table>	/s/ David H. Boruff	03/16/17	DESIGN STANDARDS ENGINEER	DATE	/s/ John Leckje	04/10/17	CHIEF ENGINEER	DATE
/s/ David H. Boruff	03/16/17								
DESIGN STANDARDS ENGINEER	DATE								
/s/ John Leckje	04/10/17								
CHIEF ENGINEER	DATE								

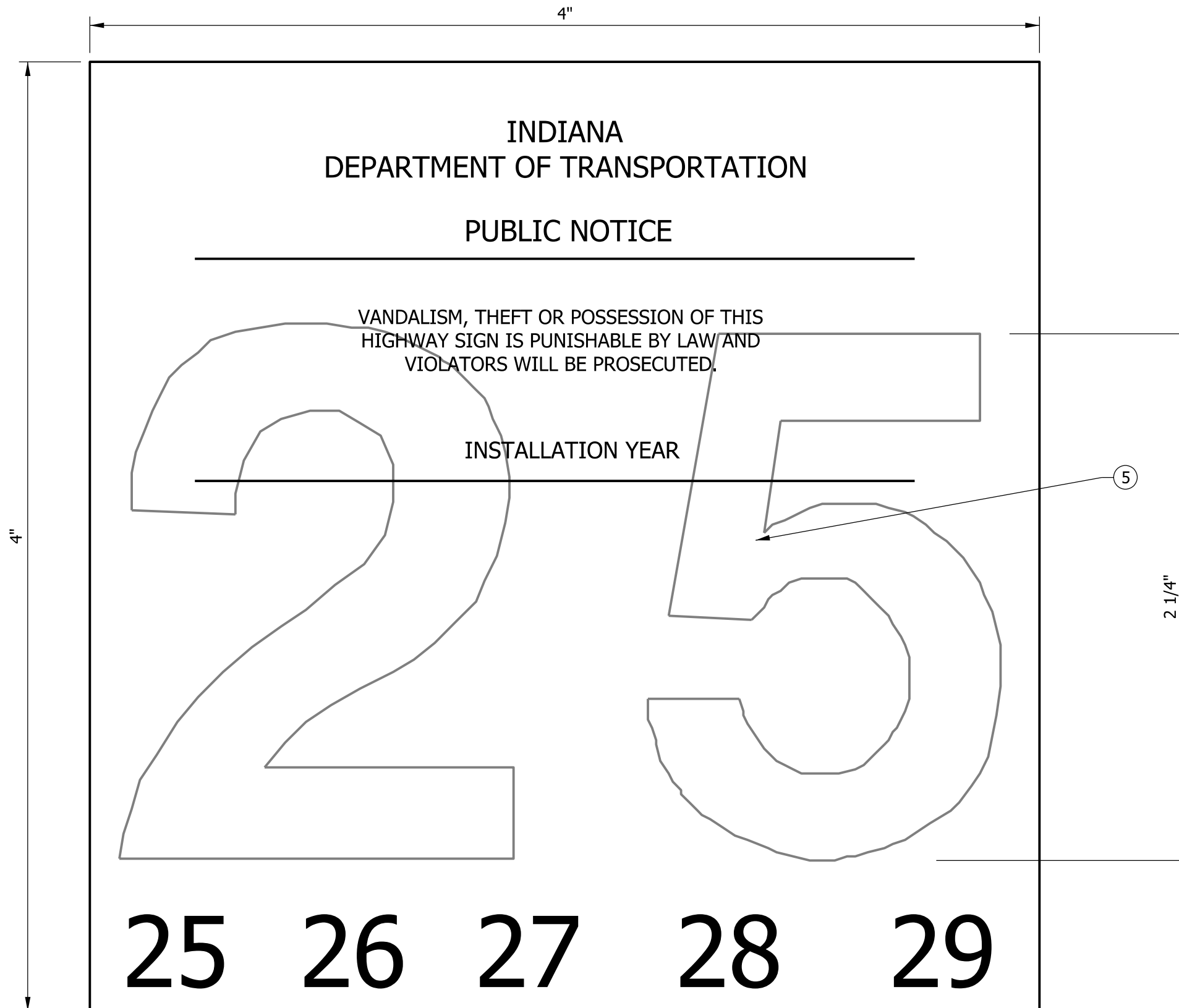

NOTES:

1. Height of lettering shall be 1/8" to 1/4". The height of the dates along the bottom shall be 1/2".
2. Copy shall be black on reflectorized white background.
3. The number of dates along the bottom need not be five, and the first date need not be 25. However, the installation year shall be shown.
4. The overlay number is to be of colored transparent sheeting to indicate the last two digits of the year of installation.
- ⑤ The decade of installation shall be indicated by color of transparent sheeting:

2020 - 2029 Brown
2030 - 2039 Orange

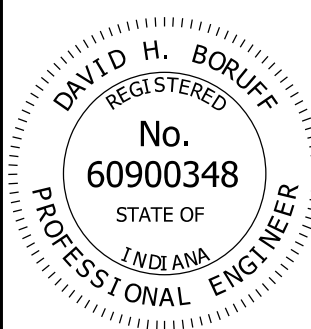
INDIANA DEPARTMENT OF TRANSPORTATION	
SIGN IDENTIFICATION MARKING	
SEPTEMBER 2026	
STANDARD DRAWING NO.	E 802-SNGS-10
	<p style="text-align: right;"><i>David H. Boruff</i> 4/28/2026 DESIGN STANDARDS ENGINEER DATE</p> <p style="text-align: right;"><i>[Signature]</i> 04/29/2026 CHIEF ENGINEER DATE</p>